

Communication Protocol

The communication network is partitioned into the following multiple layers;



- Physical layer – handles the mechanical and electrical details of the physical transmission of a bit stream.
- Data-link layer – handles the *frames*, or fixed-length parts of packets, including any error detection and recovery that occurred in the physical layer.
- Network layer – provides connections and routes packets in the communication network, including handling the address of outgoing packets, decoding the address of incoming packets, and maintaining routing information for proper response to changing load levels.



Operating System Concepts

15.1

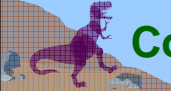
Silberschatz, Galvin and Gagne ©2002



Communication Protocol (Cont.)

- Transport layer – responsible for low-level network access and for message transfer between clients, including partitioning messages into packets, maintaining packet order, controlling flow, and generating physical addresses.
- Session layer – implements sessions, or process-to-process communications protocols.
- Presentation layer – resolves the differences in formats among the various sites in the network, including character conversions, and half duplex/full duplex (echoing).
- Application layer – interacts directly with the users' deals with file transfer, remote-login protocols and electronic mail, as well as schemas for distributed databases.



Operating System Concepts

15.2

Silberschatz, Galvin and Gagne ©2002



Communication Via ISO Network Model

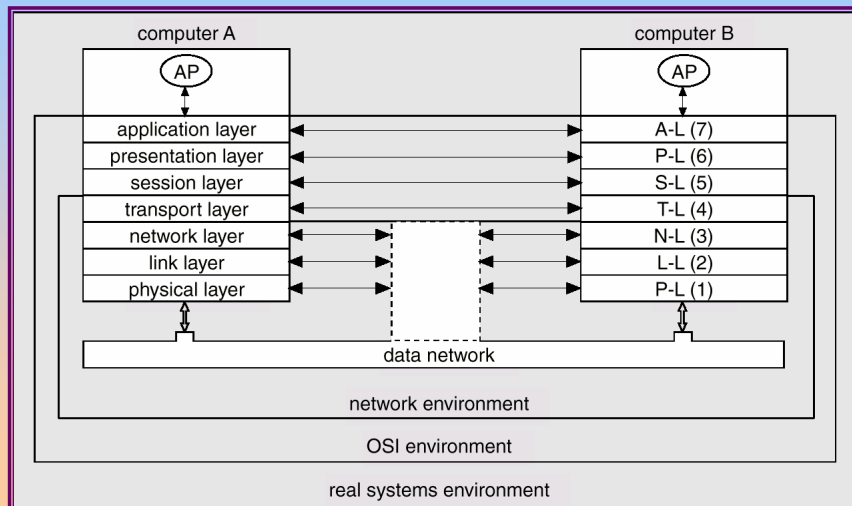

The ISO Protocol Layer

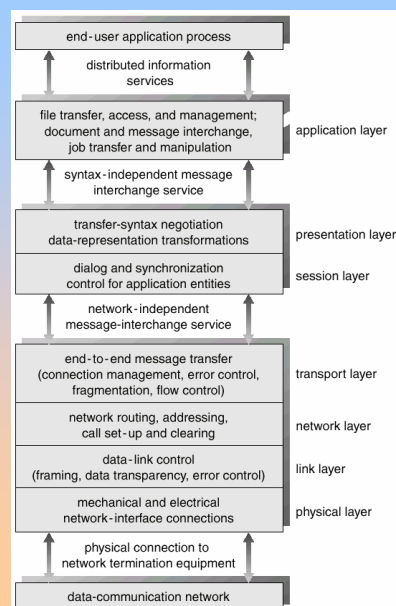

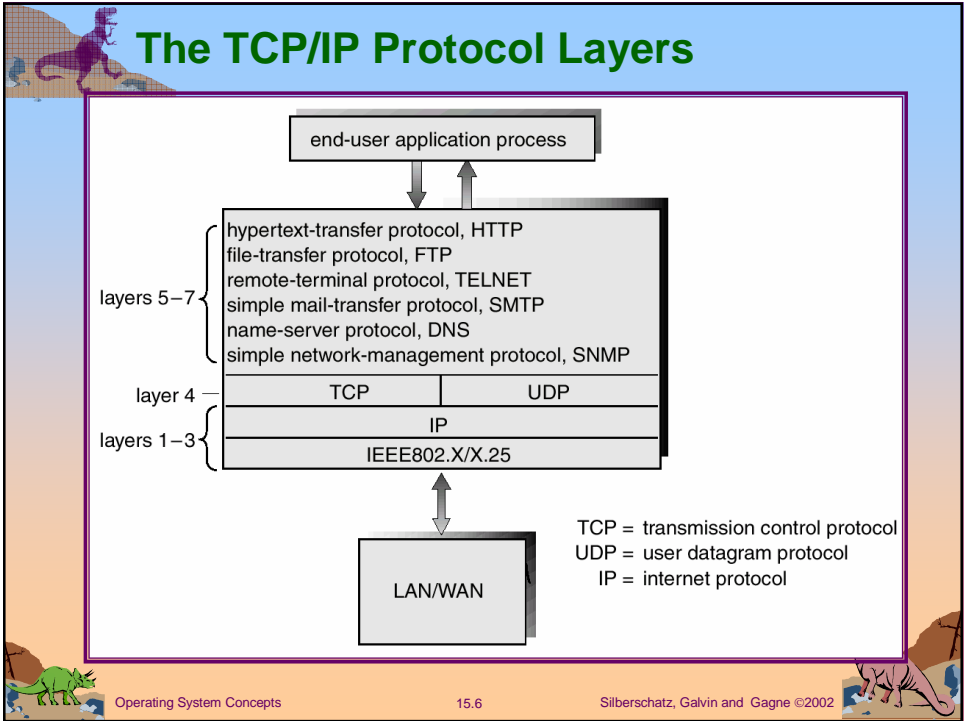
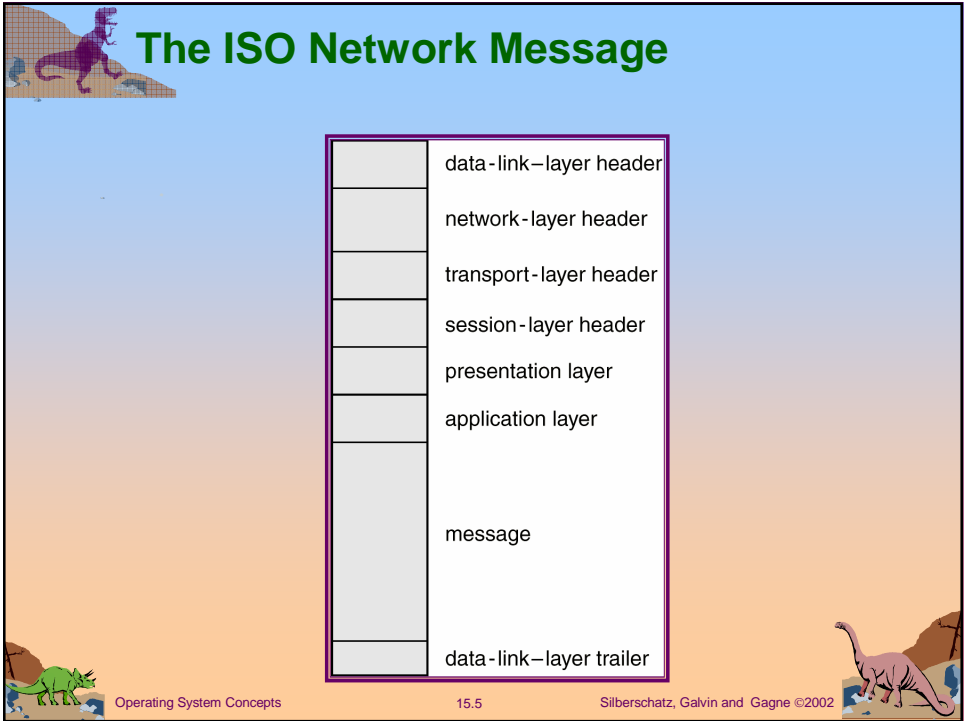

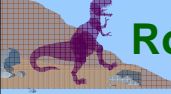

Robustness



- Failure detection
- Reconfiguration



Operating System Concepts

15.7

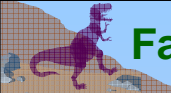
Silberschatz, Galvin and Gagne ©2002



Failure Detection

- Detecting hardware failure is difficult.
- To detect a link failure, a handshaking protocol can be used.
- Assume Site A and Site B have established a link. At fixed intervals, each site will exchange an *I-am-up* message indicating that they are up and running.
- If Site A does not receive a message within the fixed interval, it assumes either (a) the other site is not up or (b) the message was lost.
- Site A can now send an *Are-you-up?* message to Site B.
- If Site A does not receive a reply, it can repeat the message or try an alternate route to Site B.



Operating System Concepts

15.8

Silberschatz, Galvin and Gagne ©2002



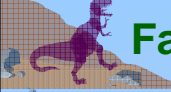

Failure Detection (cont)



- If Site A does not ultimately receive a reply from Site B, it concludes some type of failure has occurred.
- Types of failures:
 - Site B is down
 - The direct link between A and B is down
 - The alternate link from A to B is down
 - The message has been lost
- However, Site A cannot determine exactly **why** the failure has occurred.



Operating System Concepts

15.9

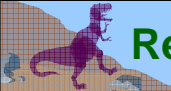
Silberschatz, Galvin and Gagne ©2002



Reconfiguration

- When Site A determines a failure has occurred, it must reconfigure the system:
 1. If the link from A to B has failed, this must be broadcast to every site in the system.
 2. If a site has failed, every other site must also be notified indicating that the services offered by the failed site are no longer available.
- When the link or the site becomes available again, this information must again be broadcast to all other sites.



Operating System Concepts

15.10



Silberschatz, Galvin and Gagne ©2002

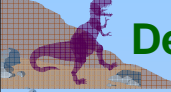



Design Issues

- **Transparency** – the distributed system should appear as a conventional, centralized system to the user.
- **Fault tolerance** – the distributed system should continue to function in the face of failure.
- **Scalability** – as demands increase, the system should easily accept the addition of new resources to accommodate the increased demand.
- **Clusters** – a collection of semi-autonomous machines that acts as a single system.



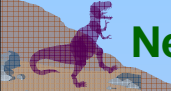

Operating System Concepts 15.11 Silberschatz, Galvin and Gagne ©2002



Networking Example

- The transmission of a network packet between hosts on an Ethernet network.
- Every host has a unique IP address and a corresponding Ethernet (MAC) address.
- Communication requires both addresses.
- Domain Name Service (DNS) can be used to acquire IP addresses.
- Address Resolution Protocol (ARP) is used to map MAC addresses to IP addresses.
- If the hosts are on the same network, ARP can be used. If the hosts are on different networks, the sending host will send the packet to a *router* which routes the packet to the destination network.



Operating System Concepts 15.12 Silberschatz, Galvin and Gagne ©2002

An Ethernet Packet

bytes		
7	preamble—start of packet	each byte pattern 10101010
1	start of frame delimiter	pattern 10101011
2 or 6	destination address	ethernet address or broadcast
2 or 6	source address	ethernet address
2	length of data section	length in bytes
0–1500	data	message data
0–46	pad (optional)	message must be > 63 bytes long
4	frame checksum	for error detection

