

Chapter 9: Memory Management

- Background
- Swapping
- Contiguous Allocation
- Paging
- Segmentation
- Segmentation with Paging

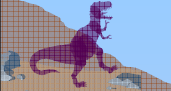

Operating System Concepts 9.1 Silberschatz, Galvin and Gagne ©2002



Background

- Program must be brought into memory and placed within a process for it to be run.
- *Input queue* – collection of processes on the disk that are waiting to be brought into memory to run the program.
- User programs go through several steps before being run.



Operating System Concepts 9.2 Silberschatz, Galvin and Gagne ©2002

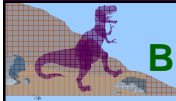

Binding of Instructions and Data to Memory

Address binding of instructions and data to memory addresses can happen at three different stages.

- **Compile time:** If memory location known a priori, absolute code can be generated; must recompile code if starting location changes.
- **Load time:** Must generate *relocatable* code if memory location is not known at compile time.
- **Execution time:** Binding delayed until run time if the process can be moved during its execution from one memory segment to another. Need hardware support for address maps (e.g., *base* and *limit registers*).

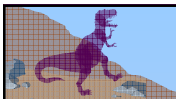

Multistep Processing of a User Program

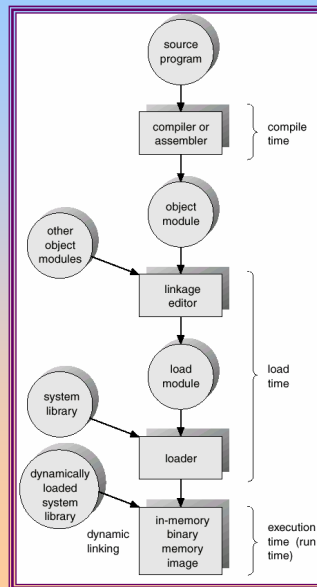



Logical vs. Physical Address Space

- The concept of a logical *address space* that is bound to a separate *physical address space* is central to proper memory management.
 - ☞ *Logical address* – generated by the CPU; also referred to as *virtual address*.
 - ☞ *Physical address* – address seen by the memory unit.
- Logical and physical addresses are the same in compile-time and load-time address-binding schemes; logical (virtual) and physical addresses differ in execution-time address-binding scheme.



Operating System Concepts 9.5 Silberschatz, Galvin and Gagne ©2002

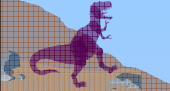

Memory-Management Unit (MMU)

- Hardware device that maps virtual to physical address.
- In MMU scheme, the value in the relocation register is added to every address generated by a user process at the time it is sent to memory.
- The user program deals with *logical* addresses; it never sees the *real* physical addresses.



Operating System Concepts 9.6 Silberschatz, Galvin and Gagne ©2002

Dynamic relocation using a relocation register

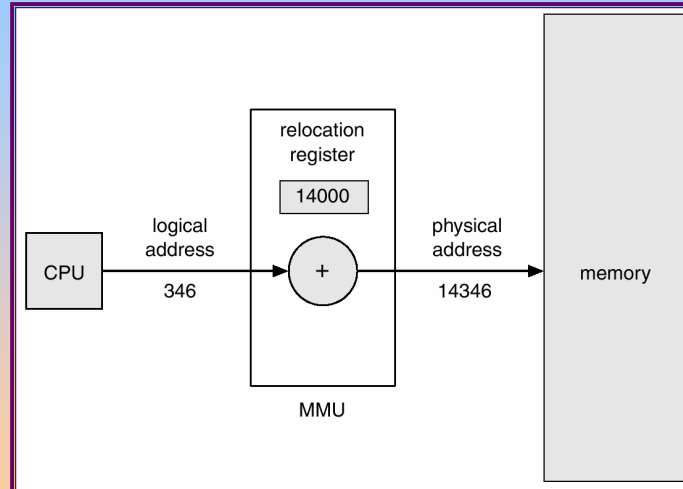

Dynamic Loading

- Routine is not loaded until it is called
- Better memory-space utilization; unused routine is never loaded.
- Useful when large amounts of code are needed to handle infrequently occurring cases.
- No special support from the operating system is required implemented through program design.



Dynamic Linking

- Linking postponed until execution time.
- Small piece of code, *stub*, used to locate the appropriate memory-resident library routine.
- Stub replaces itself with the address of the routine, and executes the routine.
- Operating system needed to check if routine is in processes' memory address.
- Dynamic linking is particularly useful for libraries.



Overlays

- Keep in memory only those instructions and data that are needed at any given time.
- Needed when process is larger than amount of memory allocated to it.
- Implemented by user, no special support needed from operating system, programming design of overlay structure is complex

Overlays for a Two-Pass Assembler

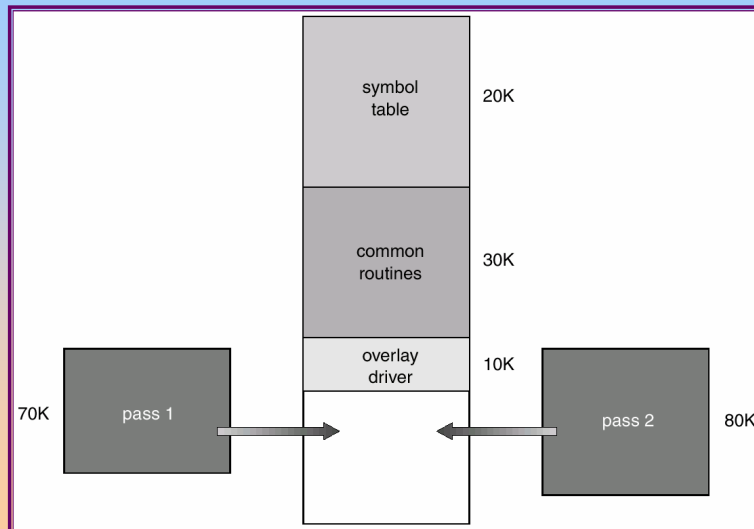

Swapping

- A process can be *swapped* temporarily out of memory to a *backing store*, and then brought back into memory for continued execution.
- Backing store – fast disk large enough to accommodate copies of all memory images for all users; must provide direct access to these memory images.
- *Roll out, roll in* – swapping variant used for priority-based scheduling algorithms; lower-priority process is swapped out so higher-priority process can be loaded and executed.
- Major part of swap time is transfer time; total transfer time is directly proportional to the *amount* of memory swapped.
- Modified versions of swapping are found on many systems, i.e., UNIX, Linux, and Windows.

Schematic View of Swapping

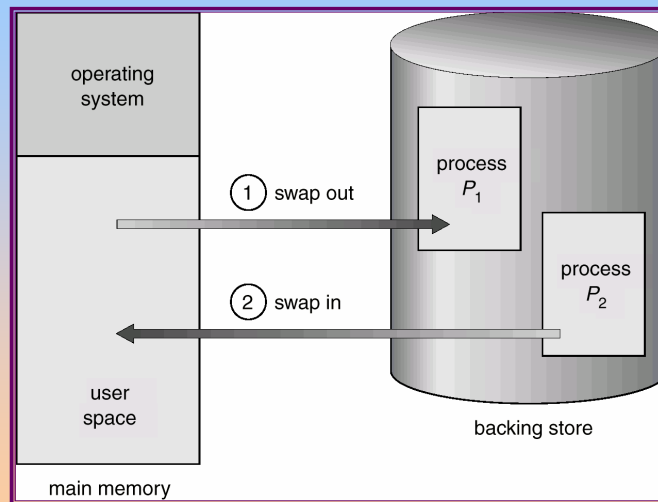

Contiguous Allocation

- Main memory usually into two partitions:
 - ☞ Resident operating system, usually held in low memory with interrupt vector.
 - ☞ User processes then held in high memory.
- Single-partition allocation
 - ☞ Relocation-register scheme used to protect user processes from each other, and from changing operating-system code and data.
 - ☞ Relocation register contains value of smallest physical address; limit register contains range of logical addresses – each logical address must be less than the limit register.

Hardware Support for Relocation and Limit Registers

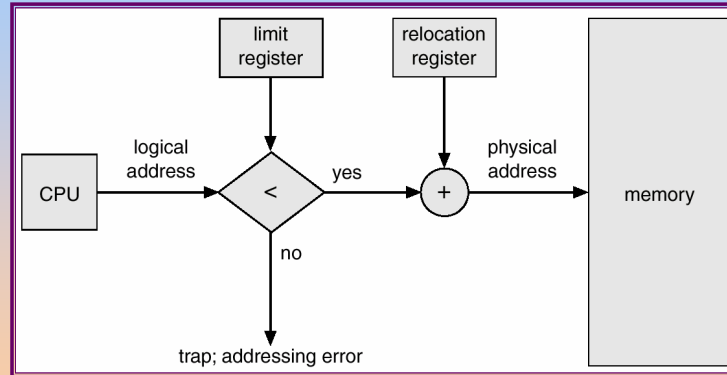

Contiguous Allocation (Cont.)

■ Multiple-partition allocation

- ☞ *Hole* – block of available memory; holes of various size are scattered throughout memory.
- ☞ When a process arrives, it is allocated memory from a hole large enough to accommodate it.
- ☞ Operating system maintains information about:
 - a) allocated partitions
 - b) free partitions (hole)

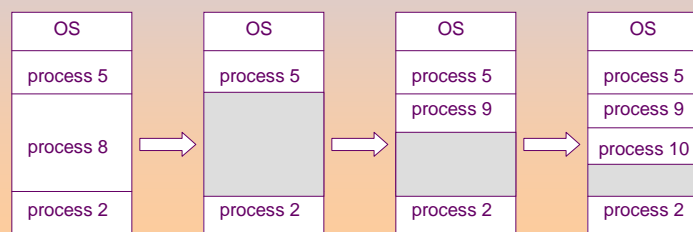

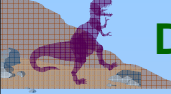

Dynamic Storage-Allocation Problem

How to satisfy a request of size n from a list of free holes.

- **First-fit:** Allocate the *first* hole that is big enough.
- **Best-fit:** Allocate the *smallest* hole that is big enough; must search entire list, unless ordered by size. Produces the smallest leftover hole.
- **Worst-fit:** Allocate the *largest* hole; must also search entire list. Produces the largest leftover hole.

First-fit and best-fit better than worst-fit in terms of speed and storage utilization.



Operating System Concepts 9.17 Silberschatz, Galvin and Gagne ©2002

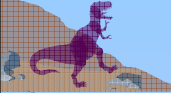

Fragmentation

- **External Fragmentation** – total memory space exists to satisfy a request, but it is not contiguous.
- **Internal Fragmentation** – allocated memory may be slightly larger than requested memory; this size difference is memory internal to a partition, but not being used.
- Reduce external fragmentation by compaction
 - ☞ Shuffle memory contents to place all free memory together in one large block.
 - ☞ Compaction is possible *only* if relocation is dynamic, and is done at execution time.
 - ☞ I/O problem
 - 📄 Latch job in memory while it is involved in I/O.
 - 📄 Do I/O only into OS buffers.



Operating System Concepts 9.18 Silberschatz, Galvin and Gagne ©2002



Paging

- Logical address space of a process can be noncontiguous; process is allocated physical memory whenever the latter is available.
- Divide physical memory into fixed-sized blocks called **frames** (size is power of 2, between 512 bytes and 8192 bytes).
- Divide logical memory into blocks of same size called **pages**.
- Keep track of all free frames.
- To run a program of size n pages, need to find n free frames and load program.
- Set up a page table to translate logical to physical addresses.
- Internal fragmentation.



Address Translation Scheme

- Address generated by CPU is divided into:
 - ☞ *Page number (p)* – used as an index into a *page table* which contains base address of each page in physical memory.
 - ☞ *Page offset (d)* – combined with base address to define the physical memory address that is sent to the memory unit.

Address Translation Architecture

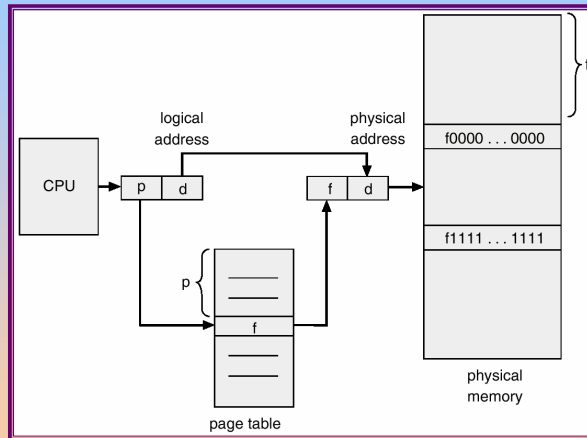

Paging Example

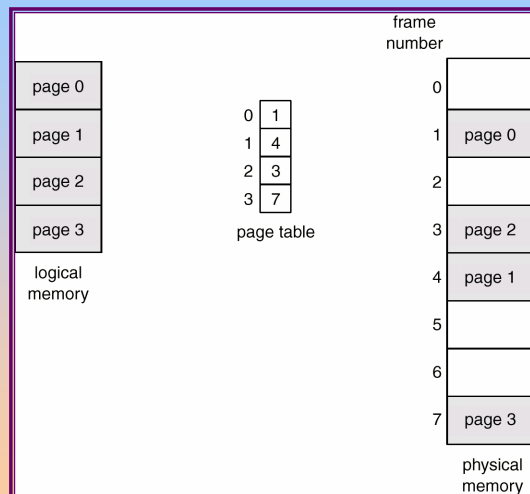

Paging Example

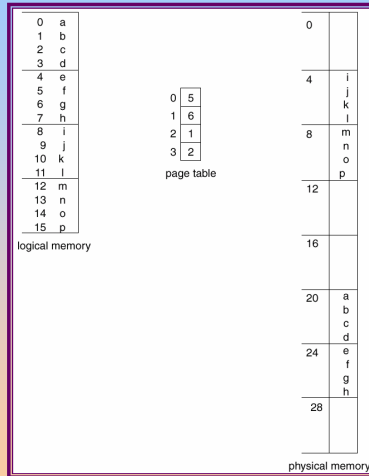

Free Frames

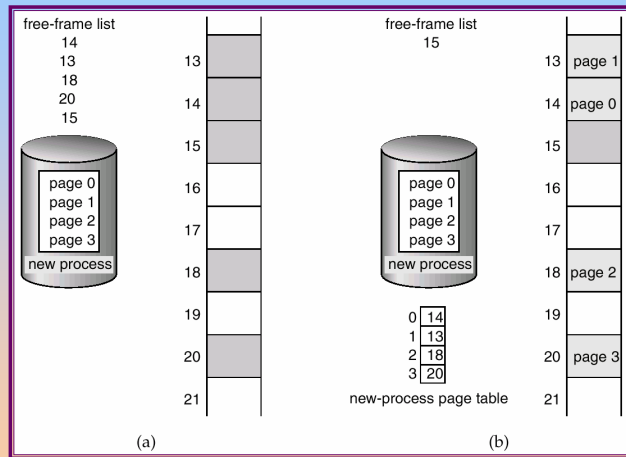

Before allocation

After allocation

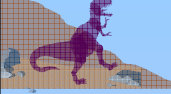

Implementation of Page Table

- Page table is kept in main memory.
- *Page-table base register (PTBR)* points to the page table.
- *Page-table length register (PRLR)* indicates size of the page table.
- In this scheme every data/instruction access requires two memory accesses. One for the page table and one for the data/instruction.
- The two memory access problem can be solved by the use of a special fast-lookup hardware cache called *associative memory* or *translation look-aside buffers (TLBs)*



Operating System Concepts 9.25 Silberschatz, Galvin and Gagne ©2002

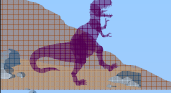

Associative Memory

- Associative memory – parallel search

Page #	Frame #

Address translation (A' , A'')

- If A' is in associative register, get frame # out.
- Otherwise get frame # from page table in memory



Operating System Concepts 9.26 Silberschatz, Galvin and Gagne ©2002

Paging Hardware With TLB

