

Embedded System Design: Modeling

Andreas Gerstlauer

Center for Embedded Computer Systems
University of California, Irvine

http://www.cecs.uci.edu/pub_slides

ASPDAC'07 Tutorial



Outline

- Requirements
- **Modeling**
 - Introduction
 - Languages and models
 - System modeling semantics
 - Automatic model generation
 - **Design example**
 - Tools
 - Summary and conclusions
- Verification and synthesis
- Summary, conclusions and outlook

ASPDAC'07 Tutorial

Copyright ©2007, CECS



2

Example: MP3 Decoder

- **Functional block diagram (major blocks only)**

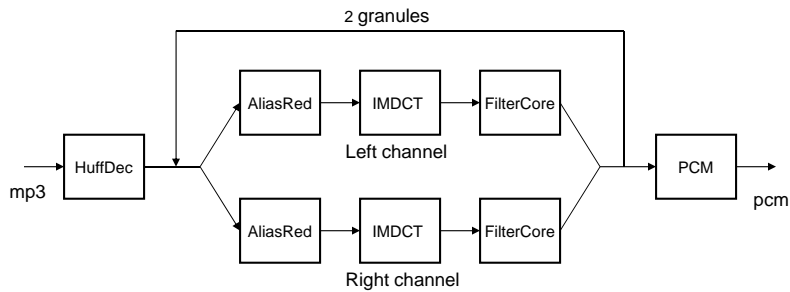

- **Timing constraints**

- 38 frames per second
- Frame delay < 26.12ms



System Definition

- **Components allocated from database**
- **Hierarchical processes inside PEs**
 - Parallel, sequential, leaf (C code)
- **Channels and variables between PEs**
- **Bridge used to interface two busses**

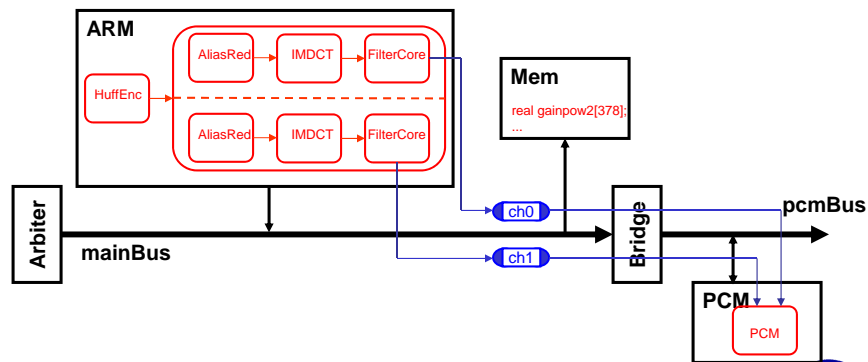

Output: Transaction-Level Model (TLM)

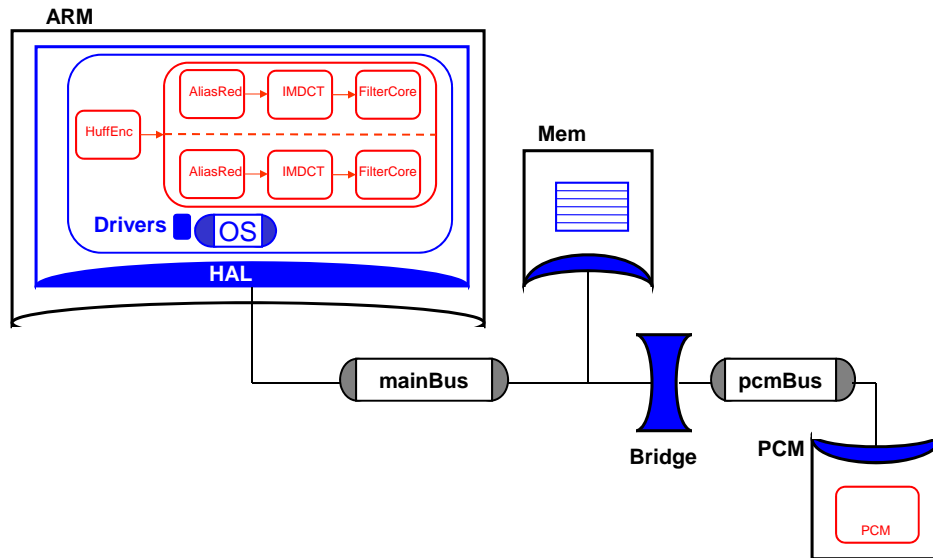

TLM Simulation

- **Timed-simulation**
 - Computation delays back-annotated in processes
 - Communication delays modeled in the bus channels
- **Simulation of TLM**
 - Functionally correct but frame delay far exceeds timing constraint

```
Terminal
File Edit View Terminal Tabs Help
***
*** Simulating MP3DecoderDEM01_Tlm ...
***
./MP3DecoderDEM01_Tlm ./testStream//spot1.mp3 MP3DecoderDEM01_Tlm.pcm ./testStream//spot1.txt
Input MP3file: ./testStream//spot1.mp3
Output bitstream file: MP3DecoderDEM01_Tlm.pcm
Bitrate = 96000 bits/sec, Sampling frequency = 44100 Samples/Sec
Initial Latency = 4.73 ms
Missed deadline per frame at frame 2 35.98 > 26.12
Missed deadline per frame at frame 3 35.98 > 26.12
***
*** Checking MP3DecoderDEM01_Tlm.pcm for correctness...
***
diff -s ./testStream//spot1.pcm MP3DecoderDEM01_Tlm.pcm
Files ./testStream//spot1.pcm and MP3DecoderDEM01_Tlm.pcm are identical
***
*** Simulation successful!
***
```



Computation Analysis

- **View computation time of processes**
 - *FilterCore* is the most computation-intensive

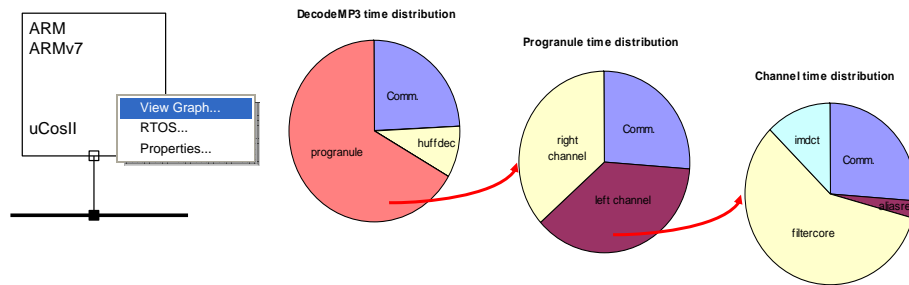

- **Look for parallelism in process hierarchy**
 - *FilterCore* processes are running in parallel
 - Use two identical custom HWs



System Modifications

- **Add two more PEs: HW1 and HW2**
- **Connect HW1 and HW2 to the mainBus**
- **Move processes from ARM to HWs**
 - Channels are automatically inserted

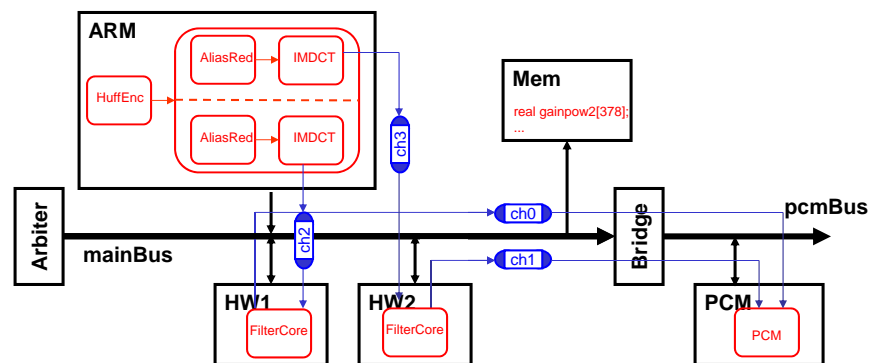

Modified TLM

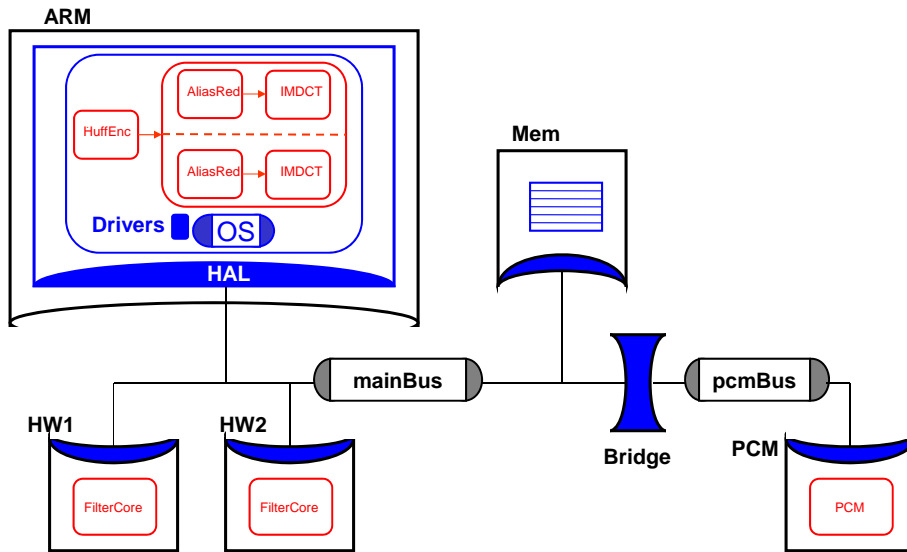

Modified TLM Simulation

- **Simulation of TLM**
 - Functionally correct
 - Frame delay still violates timing constraint

```
Terminal
File Edit View Terminal Tabs Help
***
*** Simulating MP3DecoderDEMO2_Tlm ...
***
./MP3DecoderDEMO2_Tlm ./testStream//spot1.mp3 MP3DecoderDEMO2_Tlm.pcm ./testStream//spot1.txt
Input MP3file: ./testStream//spot1.mp3
Output bitstream file: MP3DecoderDEMO2_Tlm.pcm
Bitrate = 96000 bits/sec, Sampling frequency = 44100 Samples/Sec
Initial Latency = 9.39 ms
Missed deadline per frame at frame 2 28.45 > 26.12
Missed deadline per frame at frame 3 28.45 > 26.12
***
*** Checking MP3DecoderDEMO2_Tlm.pcm for correctness...
***
diff -s ./testStream//spot1.pcm MP3DecoderDEMO2_Tlm.pcm
Files ./testStream//spot1.pcm and MP3DecoderDEMO2_Tlm.pcm are identical
***
*** Simulation successful!
***
```



Communication Analysis

- Bus utilization graph

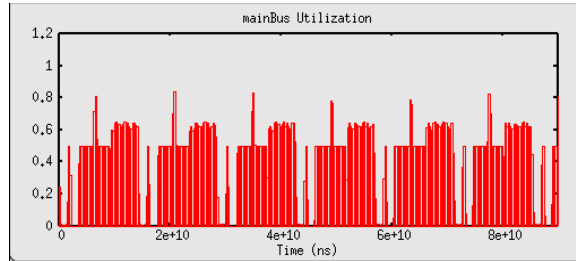

- Bus contention graph

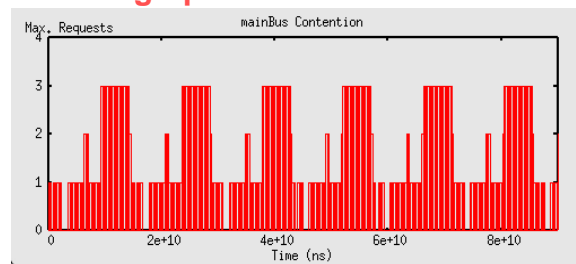

More System Modifications

- Make two ports in HW1, HW2
- Connect HWs directly to the DHS bus
- Remove the bridge

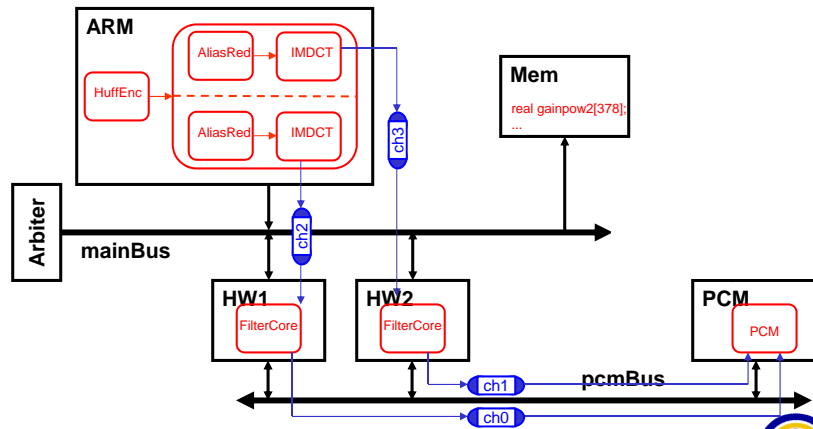

Modified TLM

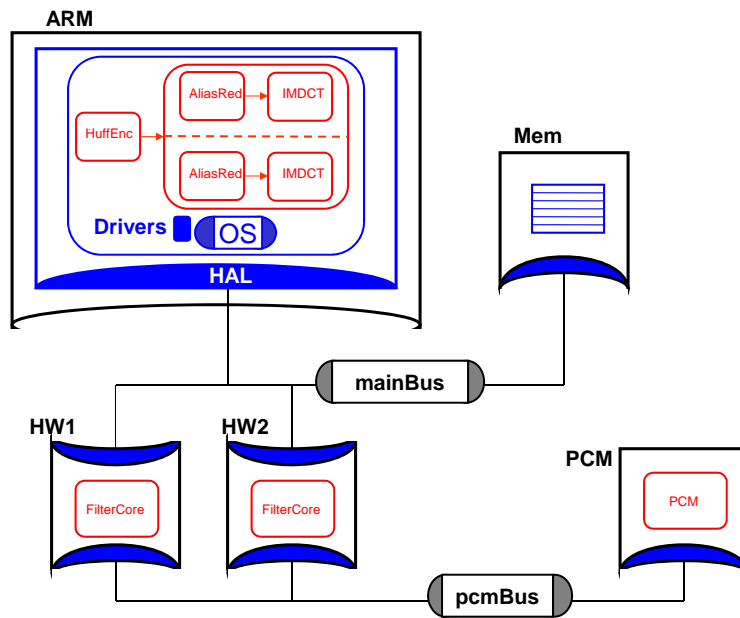

ASPDAC'07 Tutorial

Copyright ©2007, CECS



13

Modified TLM Simulation

- **Simulation of TLM**
 - Functionally correct
 - Frame delay now meets timing constraint

```
Terminal
File Edit View Terminal Tabs Help
***
*** Simulating MP3DecoderDEM03_Tlm ...
***
./MP3DecoderDEM03_Tlm ./testStream//spot1.mp3 MP3DecoderDEM03_Tlm.pcm ./testStream//spot1.txt
Input MP3file: ./testStream//spot1.mp3
Output bitstream file: MP3DecoderDEM03_Tlm.pcm
Bitrate = 96000 bits/sec, Sampling frequency = 44100 Samples/Sec
Initial Latency = 9.31 ms
Average decode time per frame at frame 2 = 25.33 ms < deadline 26.12 ms
Average decode time per frame at frame 3 = 25.33 ms < deadline 26.12 ms
***
*** Checking MP3DecoderDEM03_Tlm.pcm for correctness...
***
diff -s ./testStream//spot1.pcm MP3DecoderDEM03_Tlm.pcm
Files ./testStream//spot1.pcm and MP3DecoderDEM03_Tlm.pcm are identical
***
*** Simulation successful!
***
```

ASPDAC'07 Tutorial

Copyright ©2007, CECS



14